

EP CUBE

HOME ENERGY STORAGE SYSTEM

USER MANUAL

V 2.3



Customer Service Center

Italy
service.it@epcube.com;
<https://epcube.com/it/>
Hotline (Italy): +49 89 5199689 2528

Spain
service.es@epcube.com
<https://epcube.com/es/>
Hotline (Spain): +49 89 5199689 2529

United Kingdom
service.uk@epcube.com
<https://epcube.com/uk/>
Hotline (United Kingdom): +49 89 5199689 2525

www.epcube.com

CONTENTS

- MANUAL DESCRIPTION**
 - About This Manual ----- 1
 - General Description ----- 1
 - Abbreviated Terms ----- 1

- SAFETY INSTRUCTIONS**
 - General Notice ----- 2
 - Emergency Procedures ----- 3

- PRODUCT INTRODUCTION**
 - EP Cube Description ----- 5
 - System Topology ----- 7
 - Operation Modes ----- 8
 - Get to Know the Different Operation Modes ----- 8
 - Battery parameters ----- 12

- INSTRUCTIONS FOR USE AND MAINTENANCE**
 - Using EP Cube ----- 13
 - General Operation And Maintenance ----- 17
 - Product Update ----- 18
 - Internet Connection ----- 18
 - Disposal Instructions ----- 18
 - Warranty ----- 18

- APPENDIX 1- PRODUCT AND SAFETY LABELS**

MANUAL DESCRIPTION

Thank you very much for choosing the EP Cube HES product series. We sincerely believe that EP Cube will optimize your home energy, and look forward to your feedback on the performance of the product for improvement and better service.

About This Manual

This manual contains the product information, instructions for use and care, safety instructions, service and storage instructions, etc.

General Description

- EP Cube can only be used under conditions provided in the manual and any applicable local standards, laws and regulations. Any other use may cause personal injury and property damage.
- The illustrations and images provided in this manual are for demonstration purposes only. Actual product details may vary slightly in appearance on the installation site. Eternal planet Energy Co., Ltd ("EP") has the right to final interpretation for all the related details of the product.
- The product shall be used in a situation conforming to the design specifications. Otherwise, it may cause product failure, resulting in abnormal product function or component damage. Personal safety accidents and property loss are not within the scope of product quality assurance.
- This manual and other product-related documents are an integral part of the product and need to be properly kept for the on-site installation personnel and relevant technical personnel to review it further.

Abbreviated Terms

- AC Alternating Current
- PCS Power Conversion System
- PV Photovoltaic
- HES Home Energy Storage
- MCB Miniature Circuit Breaker

SAFETY INSTRUCTIONS

SAVE THESE INSTRUCTIONS – This manual contains important instructions for the following Models:





EP Cube HES-EU1-706G, EP Cube HES-EU1-710G, EP Cube HES-EU1-713G,
EP Cube HES-EU1-716G EP Cube HES-EU1-720G.

These instructions must be followed during installation, use and maintenance of the EP Cube system.

For personal protection and safety, please read this part carefully and strictly comply with its contents, during the entire installation and use of the product. EP is not liable for any losses caused by the violation of instructions provided in this manual.

General Notice

This part contains the following symbols with important information for safety use.

-  **WARNING:** Hot surface! To reduce the risk of burns, do not touch!
-  **DANGER:** Indicates a situation which if not avoided, can lead to death or serious injury.
-  **CAUTION:** Indicates a situation in which attention is necessary to avoid potential injury or property damage.
-  **DANGER**
 - EP Cube products are equipped with batteries that are heavy! Use of lifting equipment is recommended. Do not stack the unpacked products to avoid irreversible damage.
 - It is prohibited to touch the internal components of EP Cube when it's running. Ensure that the inverter is powered off and the AC On-Grid and AC Boost (back-up) breakers of EP Cube are always off prior to all installation, replacement, and maintenance processes.
 - Do not attempt to open, disassemble, tamper with, or modify EP Cube.
 - Do not squeeze, impact or puncture the battery, to avoid unnecessary damage and loss.
 - Do not operate EP Cube outside of the specified conditions and requirements including but not limited to standing, leaning on, or sitting on the product.
 - Do not place the EP Cube or its components in water or other liquids or expose EP Cube to flammable gases or other corrosive substances.

CAUTION

- The transportation, installation, and commissioning of the EP Cube must be carried out under the specified conditions detailed in the datasheet and installation manual. Do not expose EP Cube to conditions outside of those specified.
- EP Cube can only be installed, repaired, replaced, and maintained by licensed authorized personnel for safety and warranty purposes. Personnel must wear protective equipment during any operations.
- Do not place foreign objects on top of the product or insert them anywhere in the product. Ensure sufficient room for ventilation on top of the EP Cube.
- Do not stack more than the specified quantity of battery modules or reverse the polarity of the battery.
- Protect the EP Cube from impact when installing EP Cube in a garage or near vehicles.
- Operating or placing the EP Cube in a high temperatures environment, near heating equipment or sources of extreme heat will cause the battery modules to be thermally unstable, thereby exceeding the thermal runaway point of its material and potentially causing a fire.

Emergency Procedures

If any fault is found that may cause personal injury or product damage, the operation shall be terminated immediately, and effective protective measures shall be taken.

1. Notify all people who might be affected and ensure that they are able to evacuate the area.
2. Immediately contact the fire department or other relevant emergency response team.

In case of fire

- Turn off the Grid Circuit Breaker, AC On-Grid and AC Boost (back-up) Circuit Breakers (if available).
- Turn off the DC PV switch inside the EP Cube PCS to isolate PV input.
- Turn off the EP Cube. (Refer to Page 15)
- Acceptable fire extinguisher types are carbon dioxide-based fire extinguishers, standard ABC fire extinguishers, and dry chemical fire extinguishers.

In case of flooding

- Stay out of the water if any part of the Battery Module, EP Cube PCS, or wiring is submerged.
- Turn off the EP Cube. (Refer to Page 15)
- If possible, protect the system by finding and stopping the source of the water and pumping water away.
- If the EP Cube service team has confirmed that it is safe to re-energize, let the area dry completely before use.

In case of an unusual smell of smoke from EP Cube

- Turn off the Grid Circuit Breaker, AC On-Grid and AC Boost (back-up) Circuit Breakers (if available).
- Turn off the DC PV switch inside the EP Cube PCS to isolate PV input.
- Turn off EP Cube. (Refer to Page 15).
- Clear the area around the EP Cube HES and AC Switch Box or Service panel.
- Ventilate the room.
- Contact EP service team or your installer.

In case of EP Cube making unusual noises

- Turn off the Grid Circuit Breaker, AC On-Grid and AC Boost (back-up) Circuit Breakers (if available).
- Turn off the DC PV switch inside the EP Cube PCS to isolate PV input.
- Turn off the EP Cube. (Refer to Page 15).
- Contact the EP service team or your installer.

PRODUCT INTRODUCTION

EP Cube Description

The EP Cube HES integrates the EP Cube PCS, Battery Modules and the EP Cube Base. Accessories including the EP Cube AC Switch Box and EP Cube wall-mount kit can also be purchased separately for various installation scenarios.

A. EP CUBE HES (Reference Model: EP Cube HES-EU1-710G)

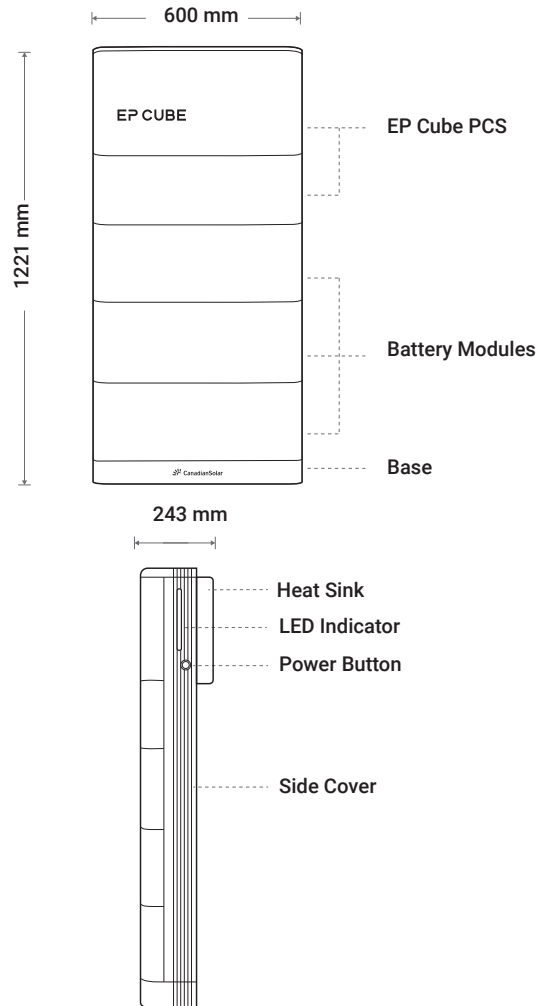

B. EP Cube AC Switch Box (optional)



C. EP Cube Wall-mount Kit (optional)

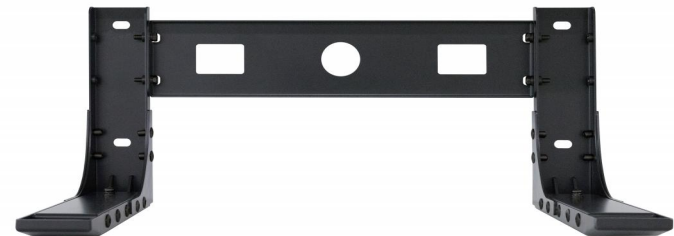

System Topology

The EP Cube HES supports partial home back-up system topology, and retrofits in any existing home electrical network. Only the back-up loads will be powered when a grid power outage occurs in partial home back-up topology.

EP Cube AC Switch Box is optional accessories. If an end-user chooses not to install the AC Switch box then the Back-up Port of the EP Cube cannot be used. The smart meter for grid and third-party inverter can be installed either in the main electrical panel or the sub-panel as per the design schematic.

The figure below shows the design schematic for a standard installation without optional AC Switch Box.

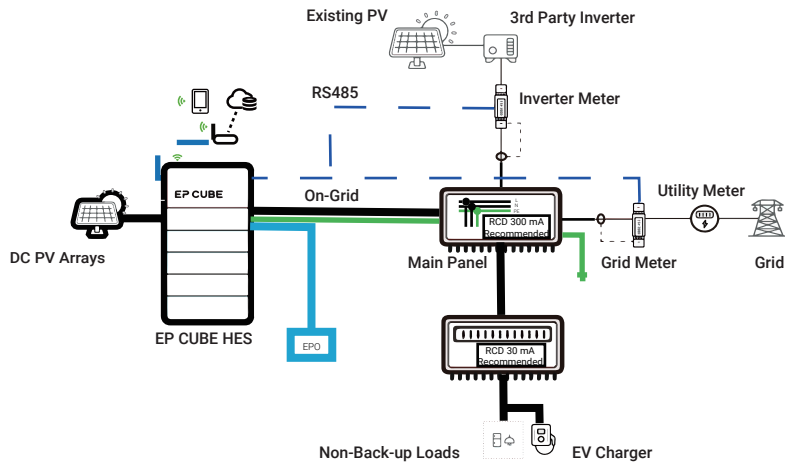

Operation Modes

The EP Cube has three different operation modes: Self-Consumption, Back-up and Time Of Use. The end-user can select the desired operation mode according to the description shown in the chart below.

Operation Mode	Description(short)
Self-Consumption	Store surplus solar energy in the battery modules, and manage it to discharge to support your home appliances when solar power is not enough.
Back-up	The end user can select the back-up mode on app to prioritize charging the battery modules as home back-up energy.
Time Of Use	Differentiate battery charge/discharge behavior during peak time and off-peak time based on your utility Time Of Use billing package to save on electricity bills.

Get to Know the Different Operation Modes

A. Self-Consumption

During self-consumption mode the power generated by PV is utilized to supply power to the connected loads as a priority. In the daytime, the PV system supplies power to loads and battery modules. Any surplus power is then used to charge the EP Cube. Power is exported to the grid only after battery modules are fully charged. When the PV generated power is not sufficient to support all the load consumption, battery modules are discharged to support the load. This mode maximizes the use of PV power.

If the PV Energy is > the Loads, the excess PV energy will charge the battery. If the battery is fully charged, and the PV energy is allowed to be exported to the grid, then the excess PV energy is exported to the grid; if the PV energy is not allowed to be exported, the PV energy will be restricted to the loads only.

If the PV Energy is < the loads, then the battery will not be charged, and grid power will be used to support the loads.

When battery reaches the reserve soc, it is not discharged to the loads. But during low power consumption state at night, the battery still provides power to EP Cube to keep system running.

Note: During off-grid operation, the battery SOC can only be discharged to 15%. This is to ensure that battery does not completely drain during prolonged grid outage or in severe weather conditions.

Once the EP Cube SOC reaches the value of Reserve SOC - set through the app - household loads will be supported by grid power. The self-consumption mode is depicted in the following figure:

PV Power Usage Priority: Load > Battery > Grid
Load Energy Source Priority: PV > Battery > Grid
Battery Charging Source: PV only

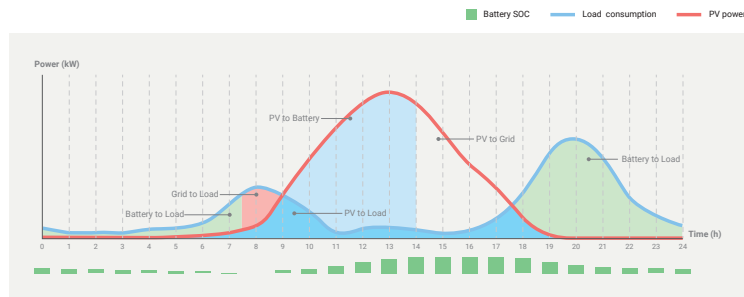

B. Backup Mode

During the back-up mode, the EP CUBE is charged until the batteries reach the SOC value set by the user. After that the batteries go into standby mode.

Battery modules are charged primarily from PV power, and if at a certain moment PV power is not enough, then batteries can be charged from the grid. If the batteries are fully charged and the SOC value set by the user is lower than 100%, the stored energy between the SOC value and the maximum battery capacity cannot be used by the loads. When a power failure or grid outage occurs, EP CUBE seamlessly switches to provide back-up power to household load.

Note: During off-grid operation, the battery SOC can only be discharged to 15%. So the value set by the user can't be lower than 15%, otherwise it can't enter the backup mode.

PV Power Usage Priority: Battery > Load > Grid
Load Energy Source Priority: Grid > PV > Battery
Battery Charging Source: PV > Grid

C. Time-of-Use (TOU):

During TOU mode user can set off-peak, mid-peak and peak hours. 3 timeslots can be set for each category.

During Off-peak hours, the EP CUBE will be charged from PV as the priority power source. If PV power is not sufficient, then the end-user can allow the EP CUBE to charge from the grid at a low price of electricity, in order to ensure that battery modules are full charged before peak hours.

Battery Charging Source: PV > Grid
Load Energy Source Priority: PV > Grid

During mid peak hours, loads are supported by PV as priority power source. Any additional consumption is covered by grid. The battery does not discharge during the mid peak hours (Except off-grid operation). PV is the only battery charging source during mid peak hours.

In case PV is available, and PV > loads, surplus PV will be used to charge the battery as much as fully charged. When the battery is fully charged, if electricity is allowed to be sold, the excess PV energy will enter the grid. If it is not allowed to enter the grid, the PV power will be limited to the load only.

PV Power Usage Priority: Load > Battery > Grid
Load Energy Source Priority: PV > Grid
Battery Charging Source: PV only

During peak hours, the EP CUBE supports the load's power consumption from PV power and battery to avoid using grid electricity at a high price. Loads are supported by PV and battery as priority power sources. Any additional consumption is covered by the grid. During peak hours, the system operation is similar to the "Self Consumption" mode. The following figure depicts the system operation during TOU mode.

PV Power Usage Priority: Load > Battery > Grid
Load Energy Source Priority: PV > Battery > Grid
Battery Charging Source: PV only

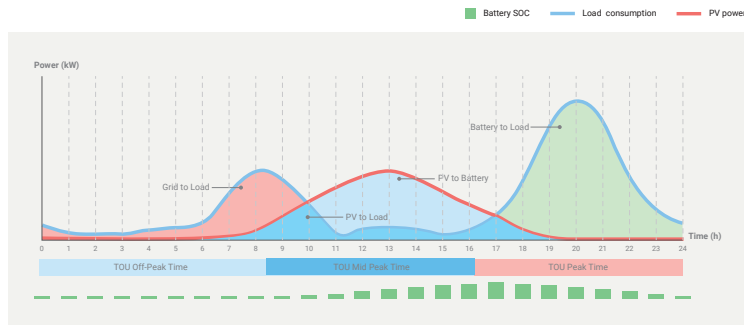

Note: During off-grid operation, in the case of no PV, there is a load, and the discharge will be carried out; the discharge ends at 15% of the off Grid reserve SOC, and the discharge will be stopped.

When there is DC PV, and PV power > load power loads, PV will charge the battery, and when the battery is fully charged, the PV will be current-limited and only used for load. If there is PV < load, PV+battery will support the loads.

Additionally, the EP Cube carries a Day-Light Saving Time (DST) function in case your peak and off peak hours change when DST is active in your time zone. It allows the user to set different off-peak and peak hours for the months when DST is enabled.

Battery parameters

Technical Specifications single Battery module	Value
Nominal capacity(kWh)	3,33 kWh
Rated charge and discharge power (kW)	1.6kW
Nominal voltage(Vdc)	38.4 V
Operating voltage (Vdc)	30 ~43,8 V
Rated Current (A)	45A
Dimensions (H x W x D)	600 x 215 x 165 mm
Weight (Kg)	34.8
IP rating	IP 65
Operating temperature	-20°C to +50°C
Operating humidity	95% non-condensing
Max. operating altitude	3000 m
Energy round trip efficiency (%)	94%
Battery cell Type	LiFePO ₄

Note: The initial capacity (design capacity) of the battery modules is 3,3 kWh. The actual capacity may vary depending on the environment conditions, such as temperature, transportation conditions, and storage conditions.

INSTRUCTIONS FOR USE AND CARE

Using the EP Cube

A. EP Cube App

The end-user is be able to monitor power and energy flow and system performance via the app.

Download the app for iOS and Android from your app store, and you can scan the QR Code to download the app.



iOS / Android App

B. How to switch ON an EP Cube

1. Turn on the Main AC Breaker in the Main Electrical Panel.
2. Turn on the AC ON-Grid Breaker and AC Boost (Back-up) Breaker inside AC Switch Box if this is present (optional).
3. Turn on the PV Switch inside the EP Cube PCS.
4. Turn on EP Cube. (Refer to section C)

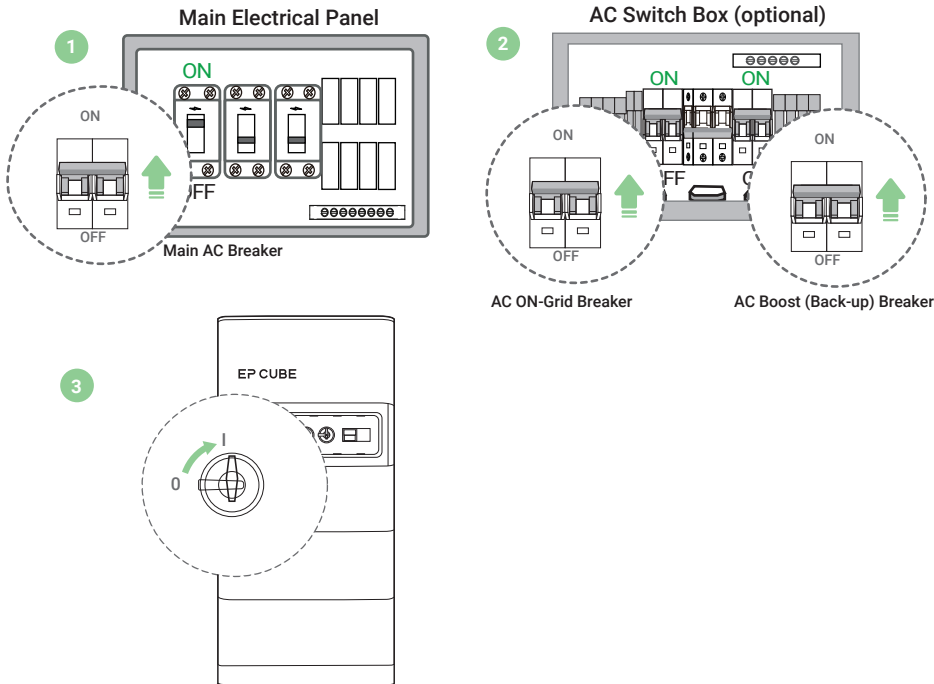

C. Turn On the EP Cube

Once the condition that EP Cube is energized. (see item B).

1. Turn on the EP Cube by pressing down the power button on the right side of the EP Cube for three seconds.

* Note: The EP Cube does not support black start i.e. if Grid and PV are down, then the system cannot be turned on.)

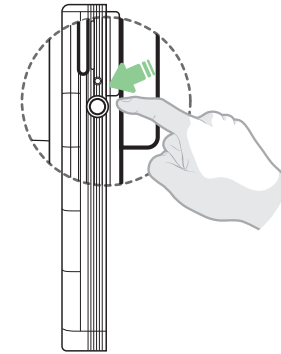

LED Status

Color	Description
	On&Working
	Flashing 05 sec./ malfunction
	Stand-by
	Flashing 10 sec./ Back-up On – Grid outage
	Off

D. Turning Off the EP Cube

1. Turn off the EP Cube by pressing the power button located on the right side of the EP Cube PCS for three seconds.

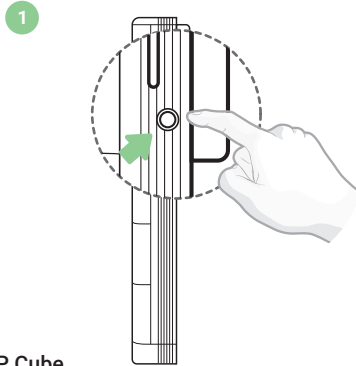

E. How to switch OFF an EP Cube

1. Turn off the EP Cube HES, (refer to section D)
2. Turn off the PV Switch inside the EP Cube PCS.
3. Turn off AC ON-Grid and AC Boost (back-up) Breakers inside the EP Cube AC Switch Box, if this is present (Optional).
4. Turn off the Main AC Breaker.

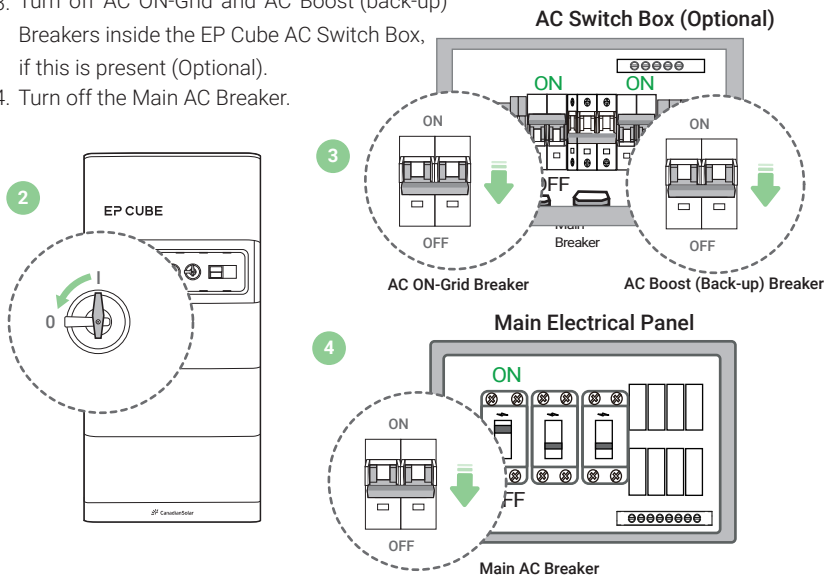

F. Disconnecting the fuse (for maintenance only)

- ⚠ Do not disconnect the fuse without the supervision of the EP authorized service team.
- ⚠ Do not disconnect the fuse during normal operation!
- ⚠ Only disconnect for maintenance once the product is powered off and de-energized.
- ⚠ After power off, wait 5 minutes to allow the components to completely discharge.

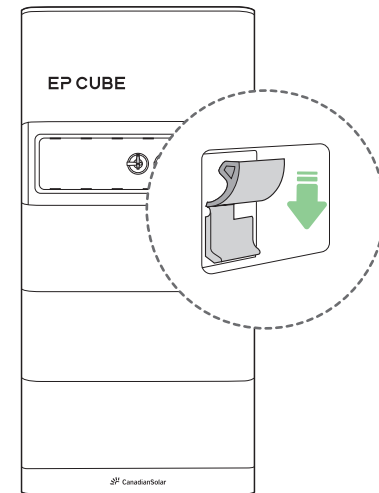

General Operation And Care

A. Operation and Maintenance

If an end-user is absent for a period of time exceeding 30 days, please ensure that:

1. The EP Cube has a dry and clean environment at an ambient temperature range of 0 °C-30 °C to protect the batteries without charge/discharge.
2. The batteries SOC (state of charge) is between 30%-50% and switch off the EP Cube HES to avoid the batteries being completely discharged.
3. Charge the batteries once every 6 months to prevent damage to the batteries i.e. using back-up or Time Of Use modes (see page 9) to force charge the batteries.

B. Visual Inspection

1. Ensure that no objects are leaning on, stacked on top of, or hanging from the EP Cube or from wires or conduit leading to the EP Cube.
2. Ensure that brackets attached to the wall are stable. Contact the EP Cube service team or your local installer if it is loose or detaching in any way.
3. Ensure that EP Cube internet connection works properly and system firmware is up to date.
4. If you notice an unusual noise or abnormal behavior, contact the EP Cube service team or your local installer for assistance.

C. Cleaning

-  Use a lint-free cloth or vacuum cleaner to remove dust and stains on the enclosure of the product. The use of organic solvents, corrosive liquids, etc. is prohibited.

Product Update

Updating the firmware to optimize performance of the EP Cube is of primary importance. Enable the OTA (Over-the-Air) function on the update page of mobile app. With this, your product will be updated automatically whenever a new firmware is available.

Internet Connection

EP Cube connects to the internet through home ethernet and WIFI networks (2.4G).

When offline:

Go to the "more" tab in the EP Cube App, and click "Bluetooth & WIFI" to configure your WIFI network again by choosing desired network and inputting the latest WIFI

Disposal Instruction

The EP Cube HES is an electronic product, do not dispose of with household waste. The EP Cube has integrated battery modules and proper disposal of the lithium batteries is required. Refer to your local codes and regulations related to disposal of lithium batteries.

Warranty

Check the *Limited Warranty* information **within 45 days** from the product installation date and ensure that the EP Cube has internet access for better aftersales service experience.

Refer to Limited Warranty for more details.





Check your warranty information in the EP Cube App, find it by clicking on "More" button and then clicking on "Warranty Information".





Check the *Limited Warranty* status on the portal: <http://epcube.com/eu/>

Click: Top menu >> Support >> Warranty >> Input the serial number of the device (PCS).





If the warranty is not available, please contact your local installer or the EP Cube Service team.

APPENDIX 1- PRODUCT AND SAFETY LABELS

EP CUBE	
	EP Cube HES-EU1-706G <input type="checkbox"/> EP Cube HES-EU1-710G <input type="checkbox"/> EP Cube HES-EU1-713G <input type="checkbox"/> EP Cube HES-EU1-716G <input type="checkbox"/> EP Cube HES-EU1-720G <input type="checkbox"/>
HYBRID INVERTER PARAMETERS	
Model	EP Cube PCS-EU1-7G
PV SPECIFICATIONS	
Max PV input voltage	600Vdc
MPPTs	2
Number of input per MPPT	1
Max. PV power per MPPT	5kWp
MPPT voltage range	90~550Vdc
Max. MPPT input current per MPPT	16Aac
Max. MPPT short circuit per MPPT	20Aac
AC SPECIFICATIONS	
Nominal grid voltage	1ph / L+N+PE / 230Vac
Nominal frequency	50Hz
Power factor	0.8ind.~0.8cap.
Max. continuous power (On-Grid side)	4.6kW <input type="checkbox"/> 5kW <input type="checkbox"/> 6kW <input type="checkbox"/> 7.6kW <input type="checkbox"/>
Max. continuous current (On-Grid side)	20.0Aac <input type="checkbox"/> 21.7Aac <input type="checkbox"/> 26.1Aac <input type="checkbox"/> 33.0Aac <input type="checkbox"/>
Max. continuous power (AC-Backup side)	7.6kW
Max. continuous current (AC-Backup side)	33.0Aac
SYSTEM PARAMETERS (only available when the Batteries Modules are connected)	
Battery quantity	2 <input type="checkbox"/> 3 <input type="checkbox"/> 4 <input type="checkbox"/> 5 <input type="checkbox"/> 6 <input type="checkbox"/>
Cell technology	LiFePO ₄
Rated capacity	90Ah
Nominal capacity	6.6kWh <input type="checkbox"/> 9.9kWh <input type="checkbox"/> 13.3kWh <input type="checkbox"/> 16.6kWh <input type="checkbox"/> 19.9kWh <input type="checkbox"/>
Nominal voltage	76.8Vdc <input type="checkbox"/> 115.2Vdc <input type="checkbox"/> 153.6Vdc <input type="checkbox"/> 192Vdc <input type="checkbox"/> 230.4Vdc <input type="checkbox"/>
Max. charge / discharge current	55Aac
SYSTEM SPECIFICATIONS	
Ambient temperature (operating / recommended)	-20~50°C / 0~30°C
Ingress protection	IP65
Protective class	Class I
   	
Add:27th Floor,Building 3A,Longgang Intelligent Park,Shenzhen,China Web:www.eternal-planet.com	
Made in China	

BATTERY MODULE	
	EP Cube B1-3G
Battery type	Rechargeable Li-ion Battery (LiFePO ₄)
Rated capacity	90Ah
Nominal capacity	3330Wh
Nominal voltage	38.4VDC
Weight	35kg
Ambient operating temperature (charging)	0~50°C
Ambient operating temperature(discharging)	-20~50°C
Ingress Protection	IP65
Protective class	CLASS I
Maximum elevation	3000m
  	
	
Add: 27th Floor, Building 3A, Longgang Intelligent Park, Shenzhen, China Made in China	

SAFETY LABELS

	Maintenance of the EP Cube must only commence 5 minutes after disconnection from all external power supplies.
	5 mins
	Danger: Electrical Hazard Only certified professionals are allowed to install and operate.
	CAUTION Caution, risk of danger.
	CAUTION Read the instructions carefully before performing any operation.

